

Calypso

Programmable Bathroom Fan Heater



Features

Color

- Standard: white.

Finish

- Standard: epoxy/polyester anti-rust powder coating resistant to UV rays.

Voltage

- 240V, 1-phase.

Construction

- Steel cabinet featuring rounded corners and splash-proof construction for safe installation in the bathroom. **1**
- Easy-to-clean, removable rear-mounted filter for minimal maintenance.
- Built-in side wire covers.
- Bottom grille directs the warm air downwards, towards the centre of the room.
- Two high-limit temperature controls that will turn the heater off in case of overheating, with main power interruption reset.

Fan

- Quiet squirrel-cage fan. **2**
- Factory-lubricated motor.

Heating element

- Nickel-chromium alloy stitched wire, providing instant heat.

Control

- Programmable built-in electronic proportional-action digital thermostat, located on the front panel, for regulated heating. **3**
- Electronic timer, 5-120 minutes, for accelerated heating.
- LCD backlit display that can be used as a night light.
- Keypad lock function using a key combination with the ability to add a code for unlocking.
- Temperature display format (°C or °F).
- "On-Off" button.
- "Manual" button to choose from Comfort, Economy and Frost Protection modes.
- "Open Window" button to activate open window detection.
- "Auto" button to enable automatic operation by following the programmed heating schedule.
- Energy use indicator.
- Heating indicator light.

Installation

- Quick surface-mounted installation, with the included wall mounting bracket, that also serves as marking template.
- Flexible cable with electrical wall box cover plate included.
- Requires installation of a wall electrical box not supplied.

Warranty

- 2-year warranty against defects.
- 5-year warranty on the heating element.

Application

- Bathroom, entrance way.



As the first fan-forced heater on the market with a programmable thermostat, the Calypso's presets and personalized programs can lead to significant energy savings. The thermostat can also detect open windows.

The powerful fan combined with a timer offering 2000W of intense heat on demand ensures unparalleled comfort.



1



2



3

| Recommended installation height | | Minimum clearances | | | | | | | |
|---------------------------------|-----|--------------------|-----|-------|-----|-------|-----|-------|-----|
| | | Front | | Sides | | Above | | Below | |
| in. | mm | in. | mm | in. | mm | in. | mm | in. | mm |
| 10 | 254 | 20 | 508 | 4 | 102 | 12 | 305 | 10 | 254 |

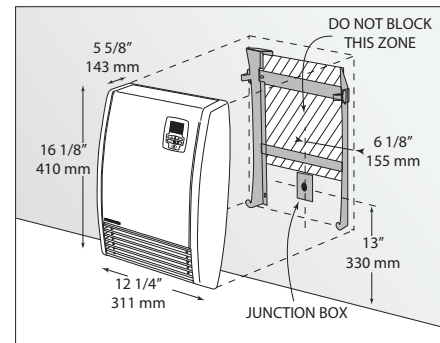

Model

| Product # | Volts | Watts | | Weight | |
|-------------|-------|----------------------------|-----------------------|--------|-----|
| | | Regulated power (standard) | Maximum power (timer) | lb | kg |
| 7826-C20-BB | 240 | 1000 | 2000 | 8.8 | 4.6 |

